

EXTERIOR FLOORS

TCNA: F102

On-Ground Concrete
Ceramic Tile

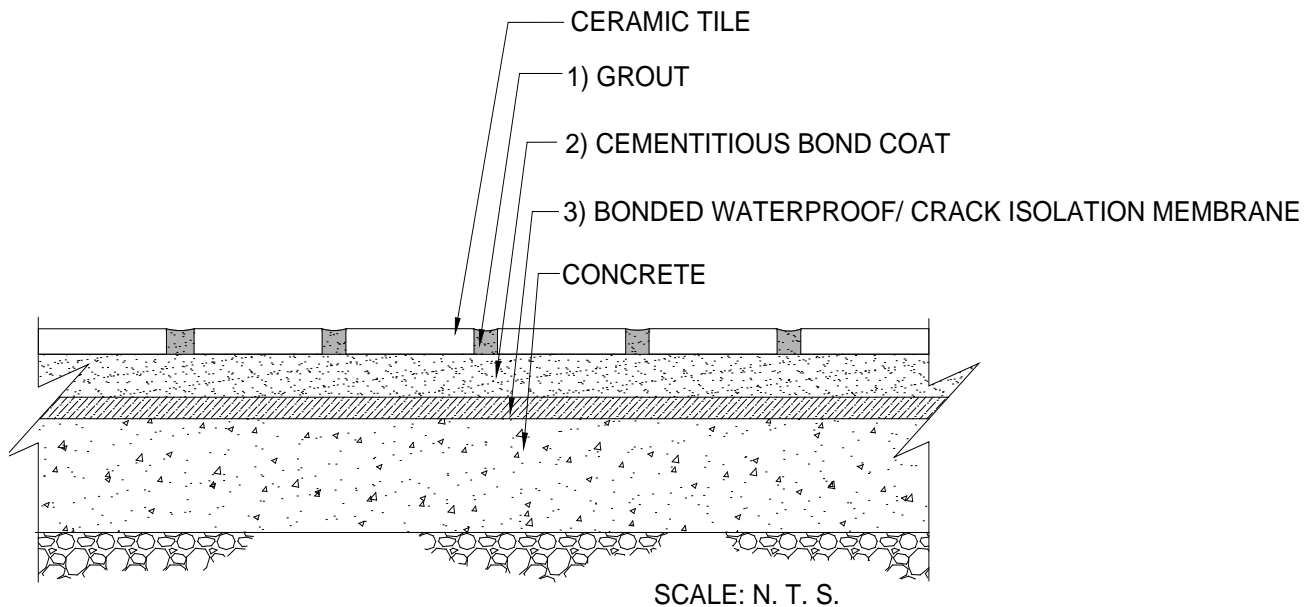

MAPEI Products Assembly

1. **Grout Options:**
 - A. *Ultracolor® Plus FA* ISO 13007 CG2WAF
2. **Cementitious Bond Coat Options:**
 - A. *Ultraflex™ LFT™* ISO 13007 C2TES1P1
3. **Waterproofing Membrane Options:**
 - A. *Mapelastic AquaDefense*

Minimum Performance Requirements from TCNA 2016 Guidelines

- Cementitious Grout: ISO 13007 CG1 or ANSI A118.6 or better
Epoxy Grout: ISO 13007 RG or ANSI A118.3 or better
Cementitious Bond Coat: ISO 13007 C2S1 or ANSI A118.4 or better

Environmental Classifications

- Residential (Res) 6
Commercial (Com) 6

Service Rating

Extra Heavy

Drawings are developed from the Tile Council of North America's (TCNA) 2016 TCA Handbook for Ceramic Tile Installation and the Terrazzo, Tile and Marble Association of Canada's (TTMAC) Tile Installation Manual. MAPEI products are listed as options and are substituted for TCNA's and TTMAC's listed ANSI and ISO (ISO 13007) standards. Please refer to the referenced handbooks and current data sheets for complete instructions and application limitations. Some installation methods and component materials are not referenced. MAPEI encourages the user to consult all approved resources to ensure a complete assembly.

MAPEI Corporation ♦ 1144 E. Newport Center Drive ♦ Deerfield Beach, Florida 33442 ♦ Phone: 954-246-8888



Guide Specification: 09 30 00
FLOORS, EXTERIOR
On-Ground Concrete
Ceramic Tile

PART 1 GENERAL

1.1 SECTION INCLUDES

- A. Tile setting mortars and adhesives.
- B. Grout for tile.
- C. Waterproofing membrane for tile.
- D. Crack isolation membrane for tile.

1.2 RELATED SECTIONS

- A. Section 09 30 00 - Tiling: Ceramic tile materials.

1.3 REFERENCES

- A. ANSI A108 Series/A118 Series - American National Standards for Installation of Ceramic Tile.
- B. ANSI A137.1 - American National Standard Specifications for Ceramic Tile.
- C. TCNA (HB) - Handbook for Ceramic Tile Installation; Tile Council of North America.
- D. ISO 13007 - International Standards Organization; classification for Grout and Adhesives.
- E. LEED® - Leadership in Energy and Environmental Design.

1.4 SUBMITTALS

- A. Submit under provisions of Section 01 30 00.
- B. [[Product Data](#)]: Manufacturer's technical information for each product specified.
- C. Samples: Color charts for selection of grout.
- D. Installation Instructions: Manufacturer's printed instructions for each product.

1.5 QUALITY ASSURANCE

- A. To ensure warranty requirements and compatibility of products; please provide all tile grout, setting materials, additives, accessories, and factory-prepared dry-set mortars from the same manufacturer.
- B. Installer Qualifications:
 - 1. Installer is [a five-star member of the National Tile Contractors Association] [or] [a Trowel of Excellence member of the Tile Contractors' Association of America]
 - 2. Installer's supervisor for the Project holds the International Masonry Institute's Foreman

Certification.

3. Installer employs [Ceramic Tile Education Foundation Certified Installers] [or] [installers recognized by the U.S. Department of Labor as Journeyman Tile Layers]

1.6 PRE INSTALLATION CONFERENCE

- A. Convene one week prior to commencing work of this section.
- B. Require attendance of installation material manufacturer, tile supplier, tile installer and installers of related work. Review installation procedures and coordination required with related work.
- C. Meeting agenda includes but is not limited to:
 1. Tile and installation material compatibility.
 2. Grouting procedure.
 3. Maintenance and cleaning products and methods.
 4. Surface Preparation.

1.7 DELIVERY, STORAGE AND HANDLING

- A. Deliver and store packaged materials in original containers with seals unbroken and labels intact until time of use. Prevent damage or contamination to materials by water, freezing, foreign matter or other causes.
- B. Do not use frozen materials unless specifically allowed by manufacturer.
- C. Deliver and store materials on site at least 24 hours before work begins.
- D. Provide heated and dry storage facilities on site.

1.8 ENVIRONMENTAL REQUIREMENTS

Comply with requirements of referenced standards and recommendations of material manufacturers for environmental conditions before, during, and after installation.

- A. For exterior applications:
 1. Build a temporary shelter and when needed use indirect auxiliary heaters to maintain an adequate temperature level in the working environment and surfaces.
 2. Exhaust temporary heaters to exterior to prevent damage to the work or injury to personnel from carbon monoxide emissions.
 3. Maintain substrate and ambient temperatures in tiled areas between 10°C (50°F) and 35°C (95°F) during installation and for at least 7 days after completion, unless otherwise indicated in the product instructions and/or ANSI A108 installation standards.

PART 2 PRODUCTS

2.1 MANUFACTURERS

- A. Acceptable Manufacturer: MAPEI Americas U.S.A., 1144 E. Newport Center Rd., Deerfield Beach, FL 33442; ASD. Toll Free Tel: 800-42-MAPEI; Tel: 954-246-8888; Fax: 954-246-8801; Email: mapeitechsvcs@mapei.com; Web: www.mapei.us
- B. Substitutions: Not permitted.
- C. Sustainability:
 1. Selected MAPEI products may help contribute to LEED® certification of projects up to two (2) points for points for MR Credit 4: Recycled content, MR Credit 5: Regional

- Materials (point are awarded based on contribution of all project materials).
2. Credit 4.2: Low-Emitting Materials – Paints & Coatings;
 3. Credit 4.3: Low-Emitting Materials – Flooring Systems.

2.2 TILE

- A. Acceptable manufacturers: Subject to conformity with the enclosed requirements, provide products coming from one of the following manufacturers:
1. Tile as Distributed by Daltile

2.3 BONDED WATERPROOFING / CRACK ISOLATION MEMBRANE

- A. Premium Latex Based Waterproofing and Crack Isolation Membrane; fast setting, flexible, thin, load-bearing, waterproofing membrane system consisting of a premixed, quick-drying liquid latex, for installation under ceramic tile complying with ANSI A118.10 and ANSI A118.12; and having IAPMO certification as a shower pan liner MAPEI, "Mapelastic AquaDefense".

2.4 MORTAR MATERIALS

- A. Modified non-sagging dry-set cement mortar for thin-set for large and heavy tile applications, complying with ANSI A118.4, A118.11 and ISO 13007 C2TES1P1; MAPEI "Ultraflex LFT".

2.5 GROUT MATERIALS

- A. Ultra premium, fine aggregate, fast-setting, polymer-modified, color-consistent, non-shrinking, efflorescence-free grout complying with ANSI A118.7 and ISO 13007; CG2WAF for joint widths from 1/16" to 3/4" (1,5 mm to 19 mm) with reduced surface absorption to help repel water, dirt and grime from penetrating grout joints, formulated with 10% recycled content and meeting ANSI A 138.1 (Green Squared) ; MAPEI "Ultracolor Plus FA"

1. Color: _____

2.6 CERAMIC TILE, SEALERS, CLEANERS AND MAINTENANCE PRODUCTS

- A. Complete line of sealers, cleaners and maintenance products for use with ceramic tile and grout
1. MAPEI "UltraCare Stone, Tile & Grout Care Solutions," www.mapei.com.

2.7 FLEXIBLE SEALANT

- A. Professional-grade, 100%-silicone sealant specifically formulated for heavy traffic expansion and movement joints, horizontal and vertical complying with ASTM standards; slump (ASTM C639), tack-free time (ASTM C679,) shore "A" hardness (ASTM C661), joint movement (ASTM C920), elongation at break (ASTM D412), flexibility (ASTM C734) and passes weatherability (Accelerated Weathering Tester QUV), Product: MAPEI "Mapesil T"

2.8 MIXES

- A. Proportion and mix materials in accordance with manufacturer's most current written instructions and applicable ANSI standards.

PART 3 EXECUTION

3.1 EXAMINATION

- A. Examine substrates for compliance with requirements for conditions affecting performance of the work. Refer to ANSI A108.01; General requirements for sub-surfaces and preparations by other trades materials or TTMAC's Tile Specification Guide 09 30 00 Tile Installation Manual.
- B. Do not proceed with tilework until surfaces and conditions comply with requirements indicated in reference tile installation standard and manufacturer's printed instructions.
- C. Installation of flooring materials indicates the acceptance of substrate.

3.2 INSTALLATION

- A. Install tile in accordance with manufacturer's printed instructions and the applicable requirements of ANSI A108 Series for the materials being used.
- B. Install tile using TCNA F102 methods specified on the drawings.
- C. Install expansion and control joints in accordance with TCNA method EJ171.

3.3 GROUTING

- A. Grout joints in accordance with manufacturer's instructions and ANSI A108.10.
- B. Clean standing water, dust, and foreign substances from joints to be grouted.
- C. Clean and dry tile surfaces.
- D. After grouting, remove all grout residues promptly.

3.4 PROTECTION

- A. Protect installed tile work from damages by other trades and general abuse until substantial work completion and acceptance.
- B. Refer to manufacturer's product data sheet for recommendations regarding protection.

END OF SECTION